



4D SYSTEMS

CB-96-G1

**Carrier Board for
uOLED-96-G1 (SGC/GFX)
Display Modules**

Document Date: 18th November 2011
Document Revision: 3.0



Description

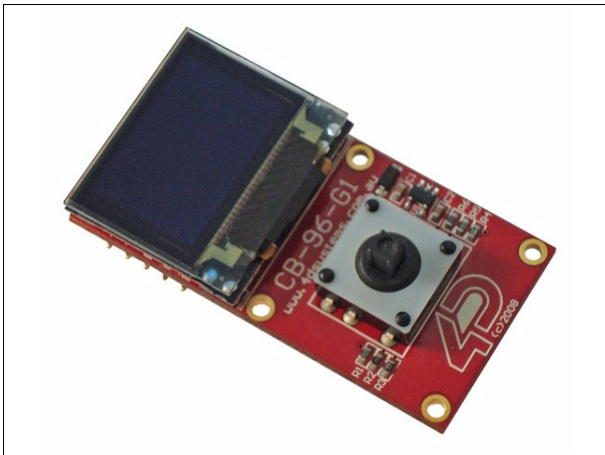

The **CB-96-G1** is a compact carrier board designed to provide a simple means of adding user input to the already capable uOLED-96-G1(SGC) (Serial Platform) and the uOLED-96-G1(GFX) (4DGL Platform) range of intelligent display modules. The tiny 5-position joystick facilitates user input for these displays.

The joystick can be used for menu navigation, exciting game play or any kind of user input needed for your applications.

The carrier board also provides a secure stable attachment for the OLED-96-G1 range of displays. When the display is mounted on the carrier board, the combination provides additional protection for the display.

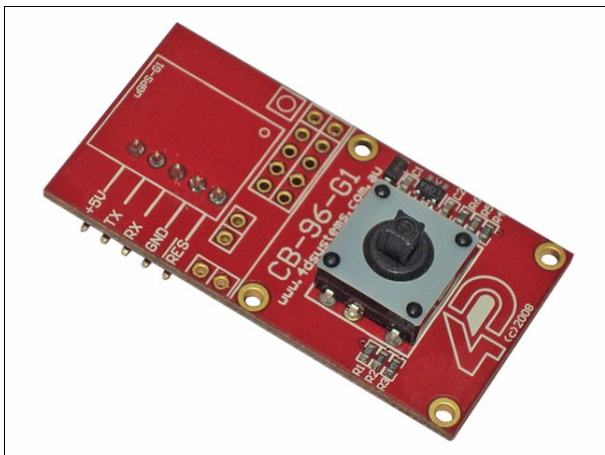

User Interface

The user interface is the 5 pin male header, underneath the board. This provides direct access to the same 5 pin header on the uOLED-96-G1 display modules (extended electrically). It is also used to attach either a uUSB-MB5 or uUSB-CE5 (USB to Serial Converters) for connecting the display module to a PC for development and programming purposes as illustrated below.

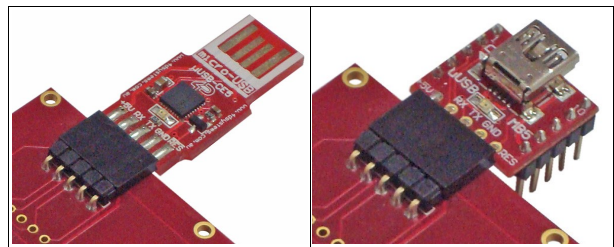
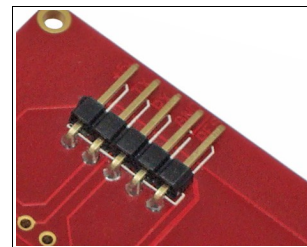
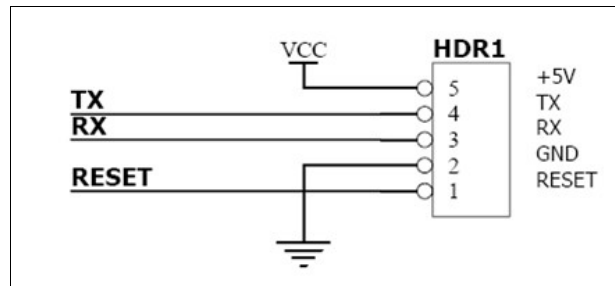

Joystick Circuit

The Joystick is a 5 position multi switch and each position connects to a junction of a resistor ladder network that forms a voltage divider.

uOLED-96-G1(SGC) Serial Display: The output of the Joystick connects directly to the **SWITCH** pin. Each Joystick position is interpreted as 1 of 5 buttons or switches.

uOLED-96-G1(GFX) 4DGL Display: The output of the Joystick voltage divider connects directly to the **IO1** pin. The IO1 pin can be programmed as an Analogue to Digital (A2D) converter input under 4DGL. Utilising the A2D feature, each individual switch position voltage value can be read and decoded. The IO1 pin of the display modules are directly connected to the output of the joystick voltage divider circuit.

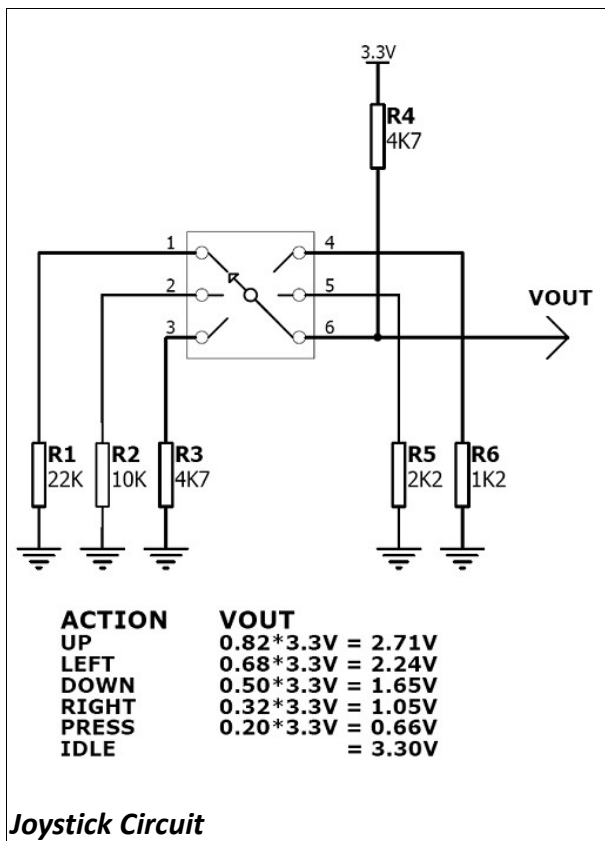

Note: The uOLED-96-G1(SGC) (Serial Platform) and the uOLED-96-G1(GFX) (4DGL Platform) display modules are both similar electrically and mechanically.

Attaching the Display Module

The following images illustrate various ways of attaching the OLED-96-G1 display modules to the CB-96-G1 carrier board.

1 The Bare Board

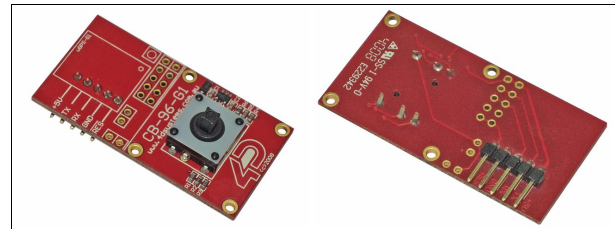

2 Display Module Directly Soldered

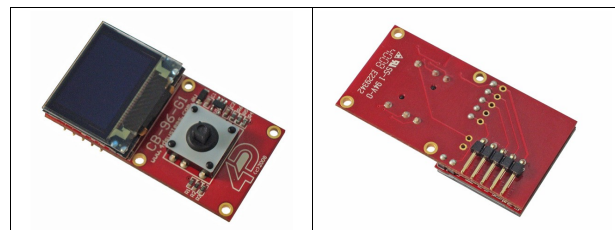

3 Display Module via Sockets

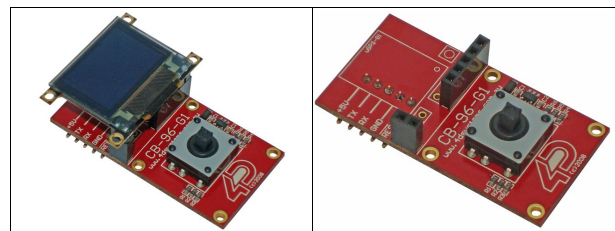

4 Interfacing the uUSB-MB5/CE5

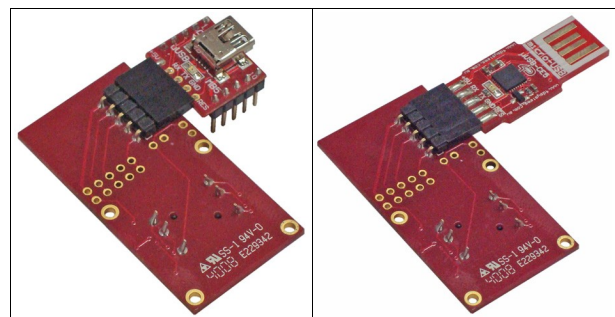

Mechanical Information

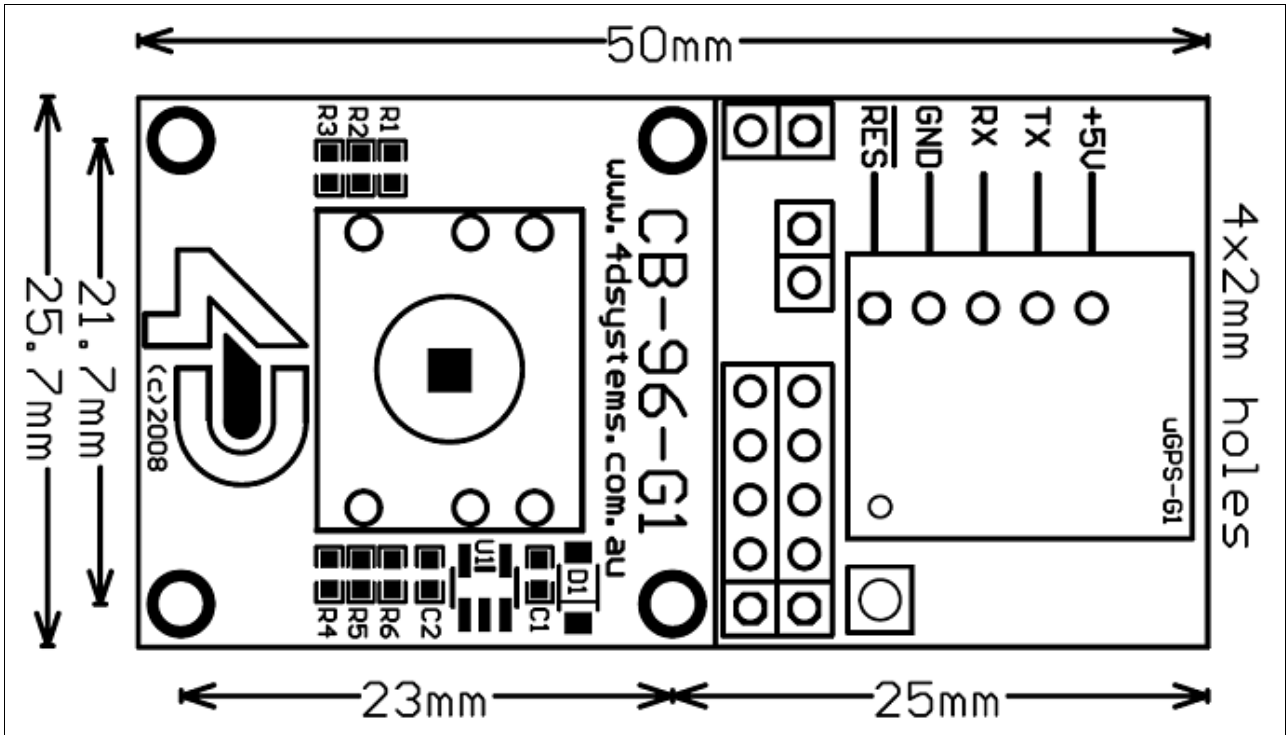

Ordering Information

Order Code: CB-96-G1
Package: 150mm x 95mm (ZIF Bag dimensions).
Packaging: Module sealed in bubble bag inside a ZIF bag, both Antistatic.

Proprietary Information

The information contained in this document is the property of 4D Systems Pty. Ltd. and may be the subject of patents pending or granted, and must not be copied or disclosed without prior written permission.

4D Systems endeavours to ensure that the information in this document is correct and fairly stated but does not accept liability for any error or omission. The development of 4D Systems products and services is continuous and published information may not be up to date. It is important to check the current position with 4D Systems.

All trademarks belong to their respective owners and are recognised and acknowledged.

Disclaimer of Warranties & Limitation of Liability

4D Systems makes no warranty, either express or implied with respect to any product, and specifically disclaims all other warranties, including, without limitation, warranties for merchantability, non-infringement and fitness for any particular purpose.

Information contained in this publication regarding device applications and the like is provided only for your convenience and may be superseded by updates. It is your responsibility to ensure that your application meets with your specifications.

In no event shall 4D Systems be liable to the buyer or to any third party for any indirect, incidental, special, consequential, punitive or exemplary damages (including without limitation lost profits, lost savings, or loss of business opportunity) arising out of or relating to any product or service provided or to be provided by 4D Systems, or the use or inability to use the same, even if 4D Systems has been advised of the possibility of such damages.

4D Systems products are not fault tolerant nor designed, manufactured or intended for use or resale as on line control equipment in hazardous environments requiring fail – safe performance, such as in the operation of nuclear facilities, aircraft navigation or communication systems, air traffic control, direct life support machines or weapons systems in which the failure of the product could lead directly to death, personal injury or severe physical or environmental damage ('High Risk Activities'). 4D Systems and its suppliers specifically disclaim any expressed or implied warranty of fitness for High Risk Activities.

Use of 4D Systems' products and devices in 'High Risk Activities' and in any other application is entirely at the buyer's risk, and the buyer agrees to defend, indemnify and hold harmless 4D Systems from any and all damages, claims, suits, or expenses resulting from such use. No licenses are conveyed, implicitly or otherwise, under any 4D Systems intellectual property rights.

Contact Information

For Technical Support : support@4dsystems.com.au

For Sales Support : sales@4dsystems.com.au

Website : www.4dsystems.com.au

Copyright 4D Systems Pty. Ltd. 2000-2011.